



Technical Data Sheet

DOWSIL™ 881 High Strength Sealant

FEATURES & BENEFITS

- Fast cure one-part acetoxy sealant
- High modulus
- High and durable adhesion to glass
- Resistant to UV exposure
- Resistant to intermittent water immersion

High modulus acetoxy silicone sealant

APPLICATIONS

- DOWSIL™ 881 High Strength Sealant is a one-part sealant particularly suitable for bonding glass where a stiff, high strength bond is required, along with a fast cure and high resistance to UV and water contact. Not suitable for structural glazing applications.

TYPICAL PROPERTIES

Specification Writers: These values are not intended for use in preparing specifications.

Test*	Property	Unit	Result
	Cure system		Acetoxy
	Standard colors		Clear, black
	Application temperature	°C °F	+5 to +30 +41 to +86
	Working time	minutes	5
CTM 97B	Specific gravity	g/ml	1.1
CTM 663A	Cure rate 23°C (73.4°F), 50% R.H.		
	1 day	mm	3.0
	7 days	mm	8.0
	2 mm thickness S2 dumb-bells (ISO¹ 37)		
CTM 137A	E-Modulus 100%	MPa	0.50
CTM 137A	Tensile strength	MPa	>2
CTM 99E	Durometer hardness, Shore A		28

*CTM: Corporate Test Method, copies of CTMs are available on request.

¹ISO: International Standardization Organization.

HOW TO USE

Surface preparation

Ensure that surfaces to be sealed are clean, dry, sound and free from grease, dust and other contaminants which could impair adhesion. Surfaces can be cleaned and degreased by wiping with a suitable solvent, such as DOWSIL™ R-40 Universal Cleaner, on a clean oil and lint-free cloth before application of sealant.

Note: When using any solvent, always provide adequate ventilation. Avoid heat, sparks and open flames. Observe and follow all precautions listed on solvent container label.

Masking

Areas adjacent to the joints should be masked with tape to prevent contamination of the substrates and to ensure a neat sealant line. Masking tape should be removed immediately after tooling.

Priming

For specific advice, please refer to the *Primers' Guide* or contact Dow for technical assistance.

Sealant application

The sealant is ready to use. Ensure complete filling of the joint in order to prevent the presence of bubbles. The sealant should have a minimum thickness of 1 mm. Tooling a triangular sealant bead inside the gap is highly recommended.

Finishing

The joint should be tooled within 5 minutes of application to ensure good contact between the sealant and the substrate. Tooling of the sealant also gives a smooth, professional finish.

Clean-up

Excess sealant may be cleaned off tools and non-porous surfaces whilst in an uncured state using DOWSIL R-40 Universal Cleaner. Care should be taken not to damage plastic or coated surfaces. Alternatively, cured silicone may be removed by peeling, cutting or other mechanical means. Care should be taken not to damage plastic or coated surfaces.

JOINT DESIGN

The sealant joint width should be designed to accommodate the movement capability of the sealant. When designing joints using this product, the minimum width should be 6 mm. For joints between 6–12 mm wide, a seal depth of 6 mm is required. For joints above 12 mm, a width to depth ratio of 2:1 should be used. In situations where fillet joints are needed, a minimum of 6 mm of sealant bite to each substrate is recommended. For joint dimensions greater than 25 mm, please contact Dow for technical assistance.

Figure 1: Deep joint.

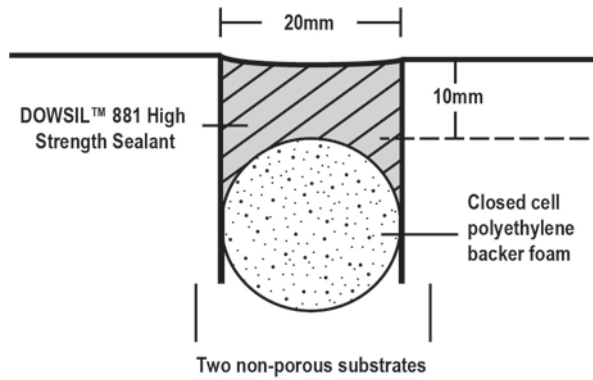

Figure 2: Shallow joint.

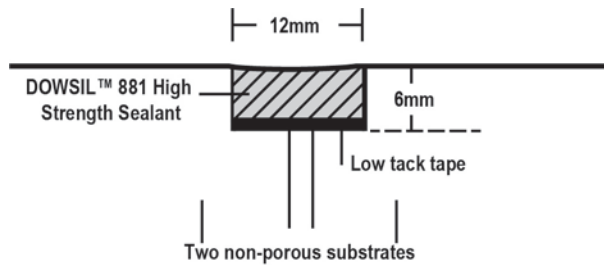
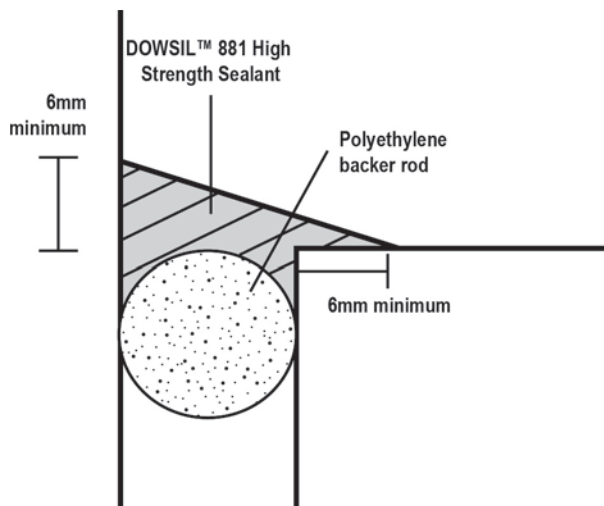

Figure 3: Fillet joint.



**HANDLING
PRECAUTIONS
PRODUCT SAFETY
INFORMATION REQUIRED FOR
SAFE USE IS NOT INCLUDED IN
THIS DOCUMENT. BEFORE
HANDLING, READ PRODUCT
AND SAFETY DATA SHEETS
AND CONTAINER LABELS FOR
SAFE USE, PHYSICAL AND
HEALTH HAZARD
INFORMATION. THE SAFETY
DATA SHEET IS AVAILABLE ON
THE DOW WEBSITE AT
WWW.CONSUMER.DOW.COM,
OR FROM YOUR DOW SALES
APPLICATION ENGINEER, OR
DISTRIBUTOR, OR BY CALLING
DOW CUSTOMER SERVICE.**

USABLE LIFE AND STORAGE

When stored in cool, dry conditions below 30°C (86°F) in the original unopened containers, DOWSIL 881 High Strength Sealant has a usable life of 18 months from the date of production.

PACKAGING INFORMATION

This product is available in 310 ml cartridges packed in boxes of 12, 400 ml sausages packed in boxes of 15, 600 ml sausages packed in boxes of 20 and 20 liter pails.

LIMITATIONS

DOWSIL 881 High Strength sealant is not recommended for use on porous substrates such as concrete, stone, marble or granite.

Do not use DOWSIL 881 High Strength Sealant on bituminous substrates, substrates based on natural rubber, chloroprene or EPDM, or on building materials and flexible plastics which might bleed oils, plasticizers or solvents.

Do not use DOWSIL 881 High Strength Sealant in a totally confined space because the sealant requires atmospheric moisture to cure. Because acetic acid is released during curing, it can corrode mirror silver and sensitive metals such as zinc, copper, brass and lead.

DOWSIL 881 High Strength Sealant is not recommended for structural glazing or insulated glazing applications.

DOWSIL 881 High Strength Sealant is not suitable in connection with laminated glass.

Delamination of PVB film may occur up to 20 mm when used in contact with the edge of laminated glass.

For sealing or gluing materials other than glass, please ensure the adhesion is sufficient for your specific application. Please contact Dow for technical assistance.

DOWSIL 881 High Strength Sealant is not suitable for food contact applications.

This product is neither tested nor represented as suitable for medical or pharmaceutical uses.

HEALTH AND ENVIRONMENTAL INFORMATION

To support customers in their product safety needs, Dow has an extensive Product Stewardship organization and a team of product safety and regulatory compliance specialists available in each area.

For further information, please see our website, www.consumer.dow.com or consult your local Dow representative.

LIMITED WARRANTY INFORMATION – PLEASE READ CAREFULLY

The information contained herein is offered in good faith and is believed to be accurate. However, because conditions and methods of use of our products are beyond our control, this information should not be used in substitution for customer's tests to ensure that our products are safe, effective, and fully satisfactory for the intended end use. Suggestions of use shall not be taken as inducements to infringe any patent.

Dow's sole warranty is that our products will meet the sales specifications in effect at the time of shipment.

Your exclusive remedy for breach of such warranty is limited to refund of purchase price or replacement of any product shown to be other than as warranted.

**TO THE FULLEST EXTENT
PERMITTED BY APPLICABLE
LAW, DOW SPECIFICALLY
DISCLAIMS ANY OTHER
EXPRESS OR IMPLIED
WARRANTY OF FITNESS FOR A
PARTICULAR PURPOSE OR
MERCHANTABILITY.**

**DOW DISCLAIMS LIABILITY
FOR ANY INCIDENTAL OR
CONSEQUENTIAL DAMAGES.**

www.consumer.dow.com

